

Needle roller bearings, with machined rings, with flanges, without an inner ring

Principal dimensions			Basic load ratings		Speed ratings	Limiting speed	Designation
F <sub>w</sub>	D	C	dynamic C	static C <sub>0</sub>	Reference speed		
mm			kN		r/min		-
<b>80</b>	95	25	56,1	127	5000	5600	<b>NK 80/25</b>

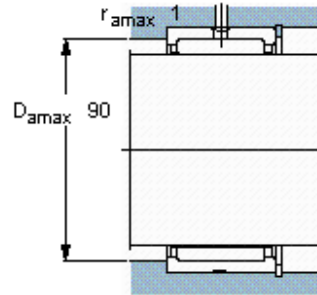
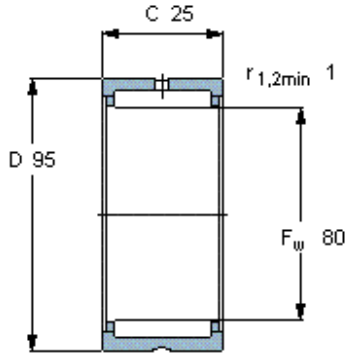

**Appropriate seals**

G seal	-
SD seal	-
CR seal	80x95x10 HMS5 RG